

SEMIX COMPACT 60

COMPACT CONCRETE BATCHING PLANTS



SMX-F-2111410859-1

PROPOSAL

BOUSTANI & PARTNERS PLANT & EQUIPMENT

Naim Irani

naim.irani@boustaninigeria.com

+234 (0)812 86 000 47

Nigeria

Delivery

12-16 Weeks

Validity Of Offer

15-09-2022

Terms Of Payment

%50 Advance, %50 Before Shipment



Description	Amount	Price	Total Price
1) COMPACT 60	1	€102.000,00	€102.000,00
1.1) TOTAL CAPACITY:60 M ³ /H	1		
1.2) MIXER TYPE & CAPACITY:1.25 M ³ SEMIX SINGLE SHAFT MIXER	1		
1.3) MIXER MOTOR POWER 37 kW	1		
1.4) AGGREGATE BIN CAPACITY:4 X 10 = 40 M ³	1		
1.5) AGGREGATE TRANSFER MECHANISM:CONVEYOR BELT	1		
1.6) AUTOMATION SYSTEM:SEMIX CONTROL SOFTWARE WITH SCHNEIDER ELECTRICAL PANEL (PC & PLC)	1		
1.7) CEMENT WEIGHING HOPPER:600 KG	1		
1.8) WATER WEIGHING HOPPER:300 KG	1		
1.9) ADDITIVE WEIGHING HOPPER:20 LITRES	1		
1.10) ADDITIVE PUMPS:1	2		
1.11) COMPRESSOR:PRESENT	1		
1.12) CONTROL CABINE:PRESENT	1		
Total:		EXW Ankara	€102.000,00
Transportation:		CIP Lagos, Nigeria	€9.000,00
Grand Total:			€111.000,00

Description	Amount	Price	Total Price
1) WAM CEMENT SILO COMPONENTS	2	€4.500,00	€9.000,00
1.1) WAM CEMENT SCREW CONVEYOR (273/10000)	2		
1.2) WAM SILO TOP FILTER	2		
1.3) WAM SILO ACCESSORIES	2		
2) OPTIONAL - PREFEEDING CONVEYOR (800 MM X 19000 MM)	1	€21.000,00	€21.000,00
Total:		EXW Ankara	€30.000,00
Transportation:		CIP Lagos, Nigeria	€9.000,00
Grand Total:			€39.000,00



Compact 60

SEMIX Compact type concrete batching plants are designed for use in small spaces and transportation factors for overseas countries.

SEMIX Compact 60 can fit on one container and assembled in 6-7 days completely.

In SEMIX Concrete Mixers NiHard4 or Hardox 450 wearings are used according to the Concrete recipe's sillicium ratio.

All SEMIX Aggregate Storage hoppers are bent trapezoidal shape to increase strength. The durable steel design maintains durable performance over many years. Aggregates are weighed in the weighing conveyor that transfers aggregates to the transfer mechanism.

All SEMIX Concrete Batching Plants are being controlled by a SCADA system with a Schneider PLC integrated. Users can follow all used materials and integrate their CRM system. SEMIX's engineering team can intervene in the Automation system online to provide service.

Overview of the Compact Concrete Batching Plant

Model : Compact 60 Concrete Batching Plant

Theoretical Production Capacity : 60 m³/h (20 seconds of mixing, C20 type of Concrete)*

Aggregate Storage Bins : 4 bins total 40 m³ storage capacity

Mixer Capacity : 1.25 m³ compacted Concrete per batch

Total Electrical Power: 90 kW , 50 Hz Frequency

**Technical changes can be made after the final examination of the engineering department.*



Designed For Small Areas

SEMIX Compact type batching plants are designed for limited spaces. Our engineering team succeeded in installing a compact type batching plant into the undermining tunnel. Thanks to its design, **SEMIX Compact Concrete Batching Plants** can be fit into areas with minimal space requirements.

SEMIX Concrete Mixers

In SEMIX Compact 60 Concrete Batching Plants, single shaft , planetary or twin shaft concrete mixers are used. Depending on the required homogeneity level of the concrete produced, either solution can be used in compact concrete batching plants.



Technical Details

Compacted Concrete Per Batch: **1.25 m³**

Dry Volume: **1.875 m³**

Motor Power: **37 kW**

Maximum Grain Size : **60-75 mm**

Mixing Blades & Wearing Plates

Mixing Blade : Ni-Hard 4 (**Chrome, Nickel special alloy cast iron**)

Stripping Blade : Ni-Hard 4 (**Chrome, Nickel special alloy cast iron**)

Internal Wearing : Hardox 450

Ni-Hard 4 : In all SEMIX Concrete Mixers, Ni-Hard 4 alloys are being used in mixer blades. NiHard4 is a white cast iron product with nickel and chromium alloying, to give a hard chromium carbide in a martensitic matrix. This structure is ideal for products under conditions of high abrasiveness and high impaction conditions.



Automatic Lubrication System

Lubrication : 4 Points Automatic Lubrication System **SKF - LINCOLN (German)**

Automatic lubrication system is integrated with the PLC and SCADA, the system periodically lubricates the necessary points and preventing from major problems. These systems use sensors to detect the level of lubricant present and dispense the appropriate amount automatically.



Product Gallery





Mixer Chassis

The main chassis was built in compliance with international requirements with a transition height of 4,100 mm to 4,250 mm with high-quality steel components and outstanding workmanship. For maneuvering and filling the truck mixer with an average width of 5,000 mm, the main chassis offers great ease. A platform, handrails, and stairs are built into the main chassis.

Supports of the chassis: UNP & INP profiles with extra cross braces



Weighing Hoppers

Cement Weighing Capacity : 600 kg

Cement Weighing Load-cells : 3 units 500 kg

Water Weighing Capacity : 300 kg

Water Weighing Load-cells : 2 units 500 kg

Additive Weighing Capacity : 1 x 20 lt (with 2 pumps)

Additive Weighing Load-cells : 1 unit 100 kg

Compressor

Brand: **Dalgakiran**

Model: D10-500

Motor Power: 7.5 kW

Piston Displacement (l/min): 1222



Aggregate Weighing Hopper

Hopper Capacity	:	1.7 m ³
Load-cells	:	Capacity of 2000kg - 4 Units
Motor Power/Gearbox	:	2 pieces FESTO Valves
Vibrator	:	200/3 – 2 Units - WAM-OLI (Italy)
Discharge Gates	:	Pneumatically driven with 2 pieces 80x200 FESTO Pistons



Weighing Hopper Equipments

Cement Discharge Valve: Ø 150 mm Butterfly Type - **WAM (Italy)**

Cement Hopper Vibrator: 1 unit - **OLI (Italy)**

Water Discharge Valve: Ø 100 Butterfly Type mm - **WAM (Italy)**

Additive Discharge Valve: 1 Unit - 1 ½" ball valve with actuator

Aggregate Storage Silos



- Storage Capacity: 4 (bins) x 10 m³ = 40 m³ **WATER VOLUME**
- Shape of the design: Square type
- Pneumatic Pistons: 4 Pistons, Festo (Germany)
- Pneumatic Valves: 4 Valves, Festo (Germany)
- Vibrators: 2 Vibrators located at the middle of discharging hatches with strengthened plate, MVE 200/3 WAM-OLI (ITALY)
- Sheet Metal: 4 + 4 millimeters S235JR steel:
- Strengthened with the extra sheet weldments for back-up.
- Trapezoidal bending process for increasing the durability



With trapezoidal bending for aggregate bin covers a high strength can be reached. In SEMIX's aggregate storage hoppers, extra reinforcement steels are welded to the empty spaces in the trapezoid. Thanks to this method, aggregate storage bins can serve long years.

Aggregate Transfer Conveyor

Belt Quality	:	EP 125 / 4 coats
Motor Power	:	GAMAK/VOLT /DIŞSAN Brand 15 kW - 1 Unit
Drums	:	10 mm Rubber Coated
Bearings	:	Lubrication Grease Nipple over SNH series
Scraper	:	V type with its weights -1 Unit
Emergency Stop Button	:	1 Unit
Pull-rope Switch	:	1 Unit
Covering over the Belt	:	Semi-closed with steel sheet



Grid Blasting Before Painting



All components of the SEMIX's concrete batching plants are treated with Grit Blasting process in SEMIX's certified grit blasting facility before the painting with steel balls. This method provides high surface finish quality after the painting.

Layout

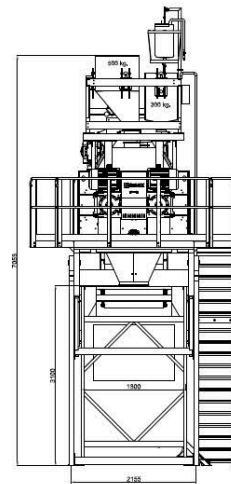
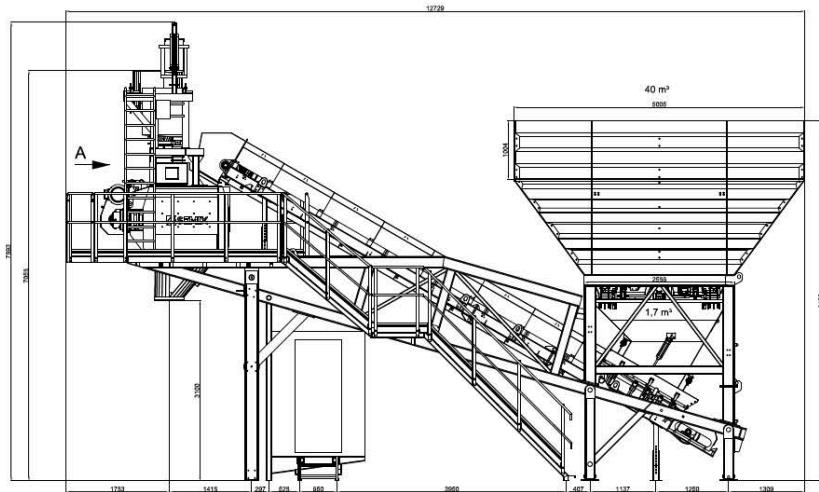

A-VIEW

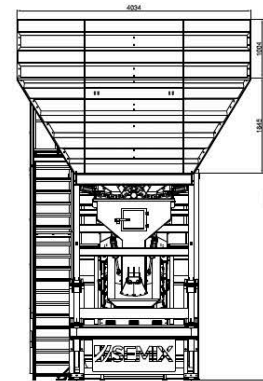
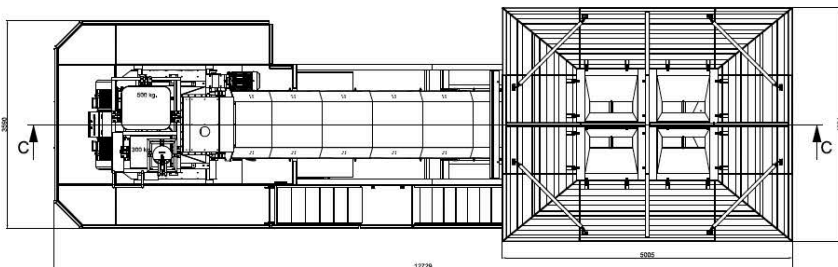

B-VIEW

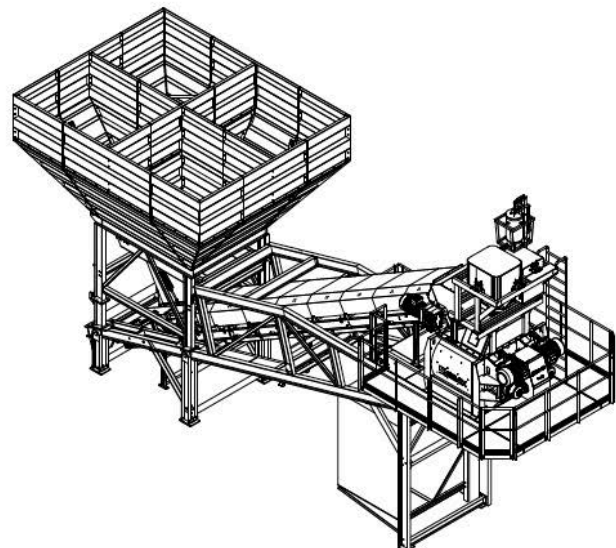
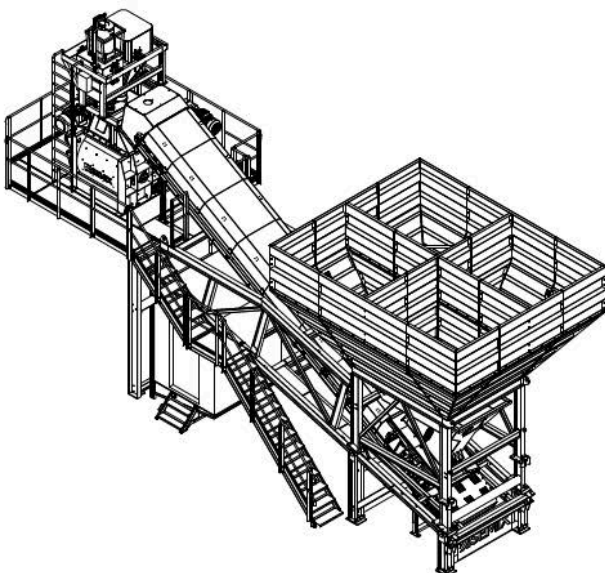
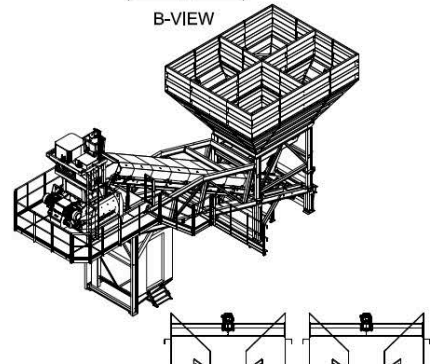
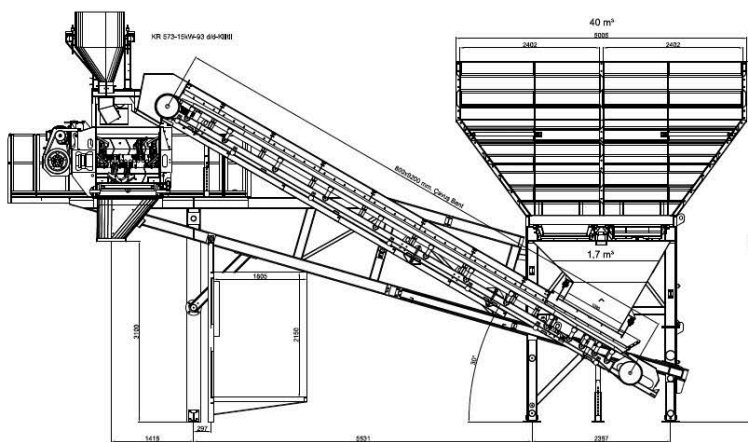

References

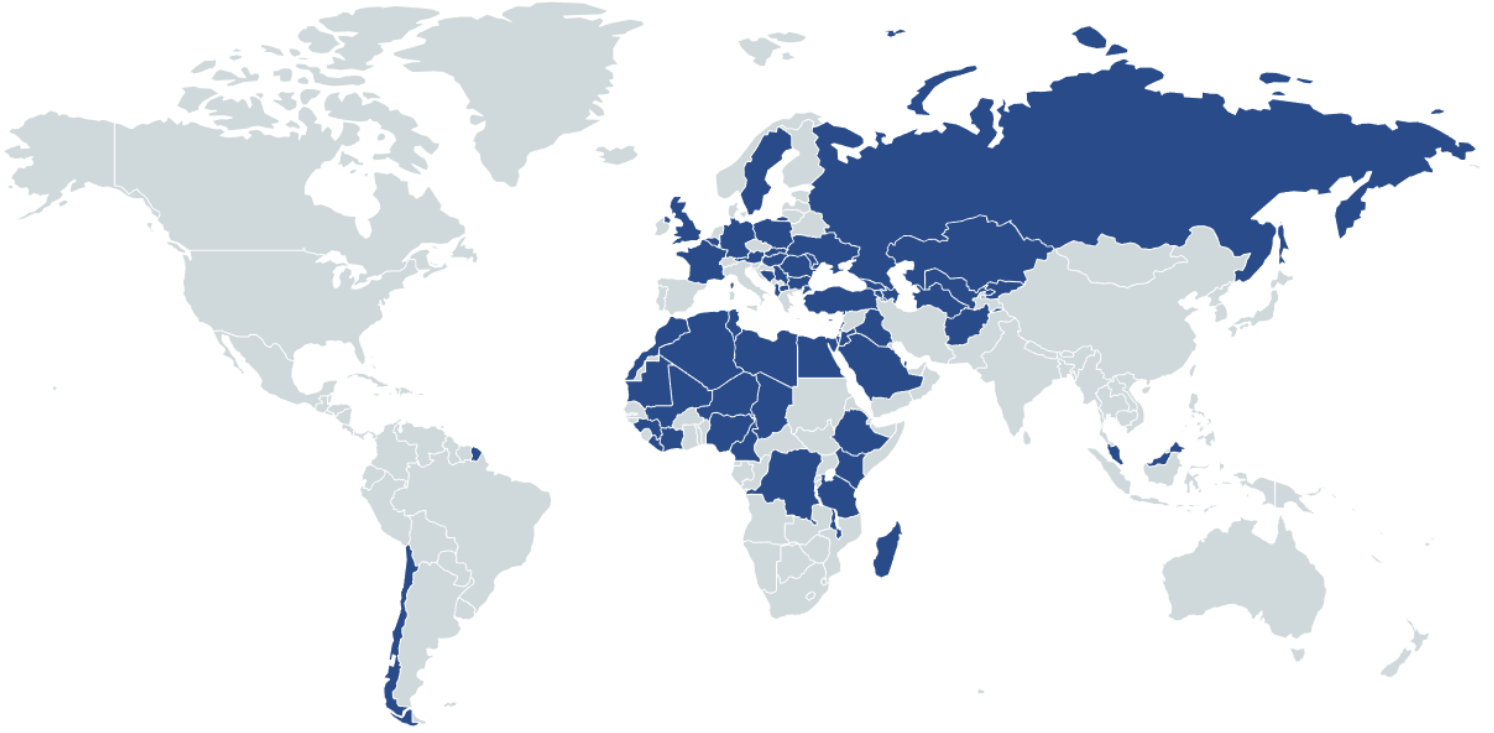

HEIDELBERG
CEMENT

STRABAG

LAFARGE



ASTALDI

clinotech

Limak

kalyon

CENGİZ
İNŞAAT



KİPAŞ HOLDİNG

ONUR
TANIMUT TİCARETLİK İNŞAAT TİC. VE SAN. A.Ş.

DANIŞ BETON
İNŞAAT SAN. TİC. A.Ş.

AKPINAR

çiftay